



Massskizze

Bei Fragen und Anregungen stehen wir Ihnen gerne zur Seite:

Faserplast AG

Sonnmattstrasse 6-8
9532 Rickenbach TG

Tel. 071 929 29 29
Mail: info@faserplast.ch
www.faserplast.ch

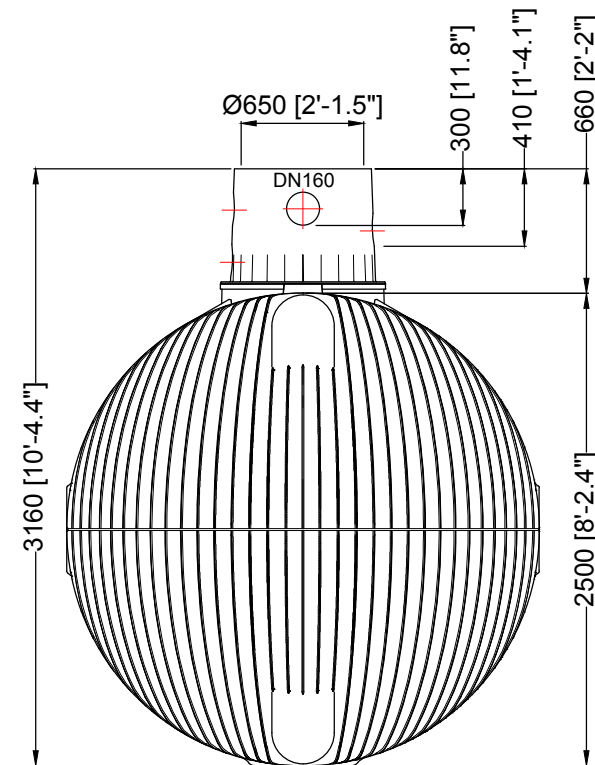
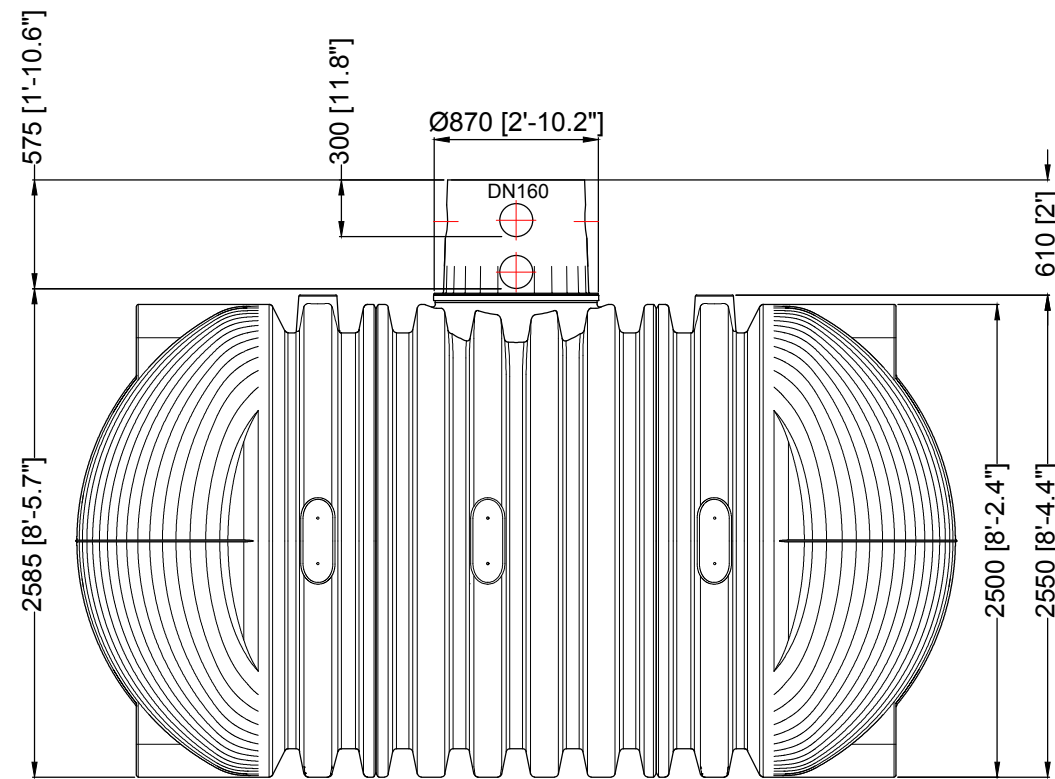
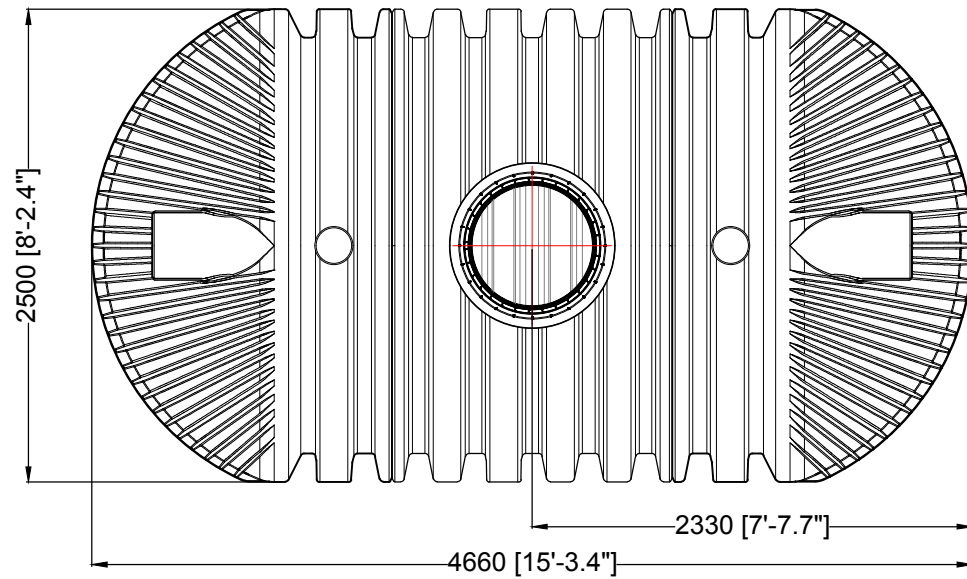

D GRAF Regenwasser-Erdtank Carat XXL 16000 L / 4226,7 gal.			Artikel-Nr. product no. article no. articulo no.	380001 (380811 / 371018)
GB GRAF underground tank Carat XXL 16000 L / 4226,7 gal.	ES GRAF Depósito soterrado Carat XXL 16000 L / 4226,7 gal.	FR GRAF Cuve à enterrer Carat XXL 16000 L / 4226,7 gal.	revision	
gezeichnet drawn EMU	Gewicht weight 810 kg	Otto Graf GmbH Carl-Zeiss-Str. 2-6 DE-79331 Teningen mail@graf.info www.graf.info		
Datum date 2018.12.12	Toleranz tolerance +/- 3%			
Maßstab scale M 1:40	Einheiten units mm [inch] gal. = US gal.			

