



Massskizze

Bei Fragen und Anregungen stehen wir Ihnen gerne zur Seite:

Faserplast AG

Sonnmattstrasse 6-8
9532 Rickenbach TG

Tel. 071 929 29 29
Mail: info@faserplast.ch
www.faserplast.ch

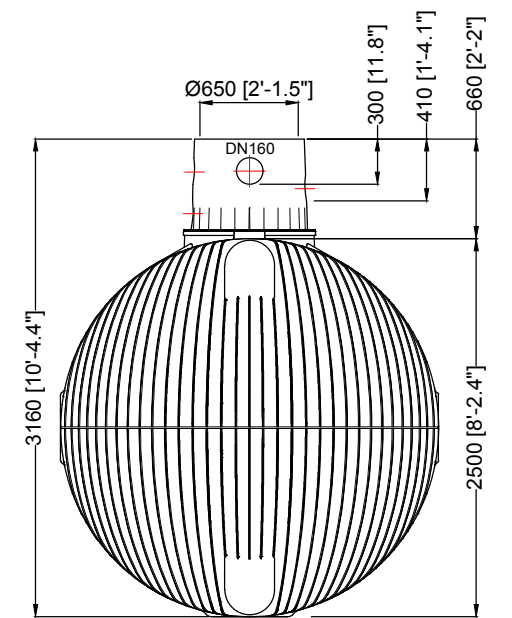
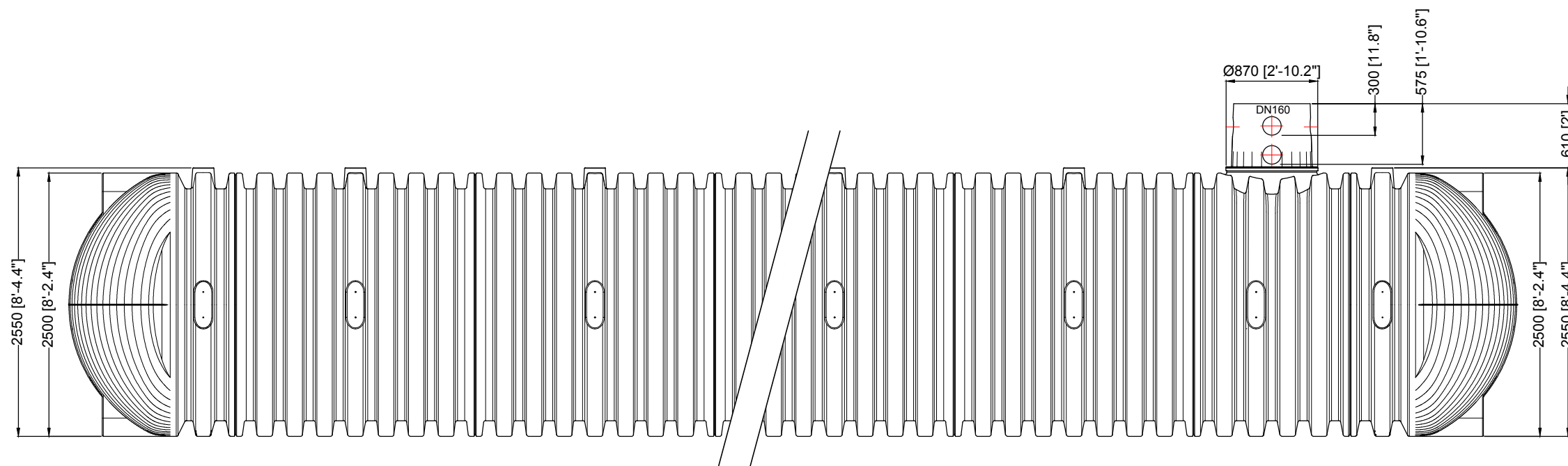
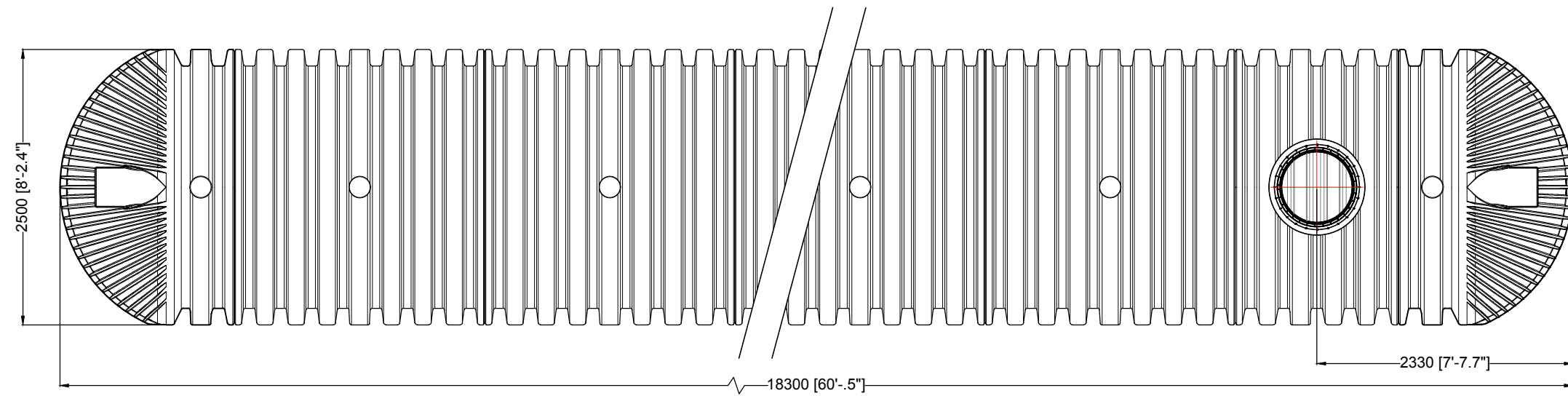

| | | | | | | |
|---------------------|--|-----------------------|--|---|---|------------------------------------|
| D | | | GRAF Regenwasser-Erdtank Carat XXL 76000 L / 20076,9 gal. | | Artikel-Nr. product no. article no. artículo no. | 380012 (380823 / 371018) |
| GB | GRAF | ES | GRAF | FR | GRAF | revision |
| | underground tank Carat XXL 76000 L / 20076,9 gal. | | Depósito soterrado Carat XXL 76000 L / 20076,9 gal. | | Cuve à enterrer Carat XXL 76000 L / 20076,9 gal. | |
| gezeichnet drawn | EMU | Gewicht weight | 3140 kg | Otto Graf GmbH Carl-Zeiss-Str. 2-6 DE-79331 Teningen mail@graf.info www.graf.info | | |
| Datum date | 2018.12.12 | Toleranz tolerance | +/- 3% | | | |
| Maßstab scale | M 1:50 | Einheiten units | mm [inch] gal. = US gal. | | | |
| | | | |  | | |